

Yard drains in *Ecoguss* / polymer

System 200 / 100

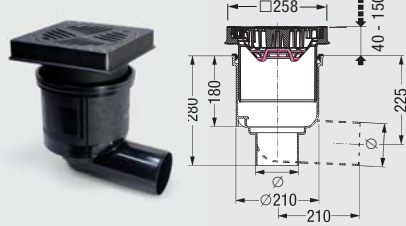
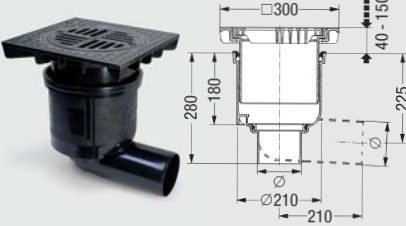

Yard drains System 200

Products

Illustration and dimensioned drawing	Article description	Outer diameter Ø (mm)	Article #
 <p>4.5 l/sec flow rate</p>	<p>Yard drains <i>Ecoguss</i> 200</p> <ul style="list-style-type: none"> <input type="checkbox"/> Lateral outlet 2.5° <input type="checkbox"/> Vertical outlet <p>with drain body made of polymer and upper section made of <i>Ecoguss</i>, upper section with square support rim, class B 125, with <i>Lock & Lift</i> System, with sludge trap</p>	<p>Ø 110</p> <p>Ø 110</p>	<p>67 923 B</p> <p>67 922 B</p>
 <p>4.5 l/sec flow rate</p>	<p>System 200 Yard drain</p> <ul style="list-style-type: none"> <input type="checkbox"/> Lateral outlet 2.5° <input type="checkbox"/> Vertical outlet <p>with drain body made of polymer, upper section with support rim, lotted cover class ...</p> <p>With lip seal and protective cover for use during construction.</p> <p>Weight: Class A 15 approx. 4.2 kg.</p> <p>Accessories: Sludge trap Art. # 67 300, odour-trap (consider frost free installation depth) Art. # 27 171 see page 240/241</p>	<p>Ø 110</p> <p>Ø 110</p>	<p>67 020.30</p> <p>67 060.30</p>

Yard drains System 100

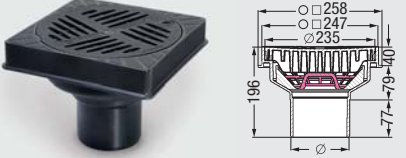
Products

Illustration and dimensioned drawing	Article description	Outer diameter Ø (mm)	Article #
 <p>4.5 l/sec flow rate</p>	<p>Yard drain <i>Ecoguss</i> pipe connection drain - square</p> <p>Vertical outlet</p> <ul style="list-style-type: none"> <input type="checkbox"/> upper section with square support rim in <i>Ecoguss</i> and round slotted cover Ø 235 mm, class B 125, with <i>Lock & Lift</i> System, with sludge trap <p>Accessories: <i>Multistop</i> Art. # 43 500 see page 208</p>	<p>Ø 110</p>	<p>67 110 B</p>
 <p>4.5 l/sec flow rate</p>	<p>Yard drain <i>Ecoguss</i> pipe connection drain - round</p> <p>Vertical outlet</p> <ul style="list-style-type: none"> <input type="checkbox"/> upper section with round support rim in <i>Ecoguss</i> and round slotted cover Ø 235 mm, class B 125, with <i>Lock & Lift</i> System, with sludge trap <p>Accessories: <i>Multistop</i> Art. # 43 500 see page 208</p>	<p>Ø 110</p>	<p>67 111 B</p>
 <p>1.6 l/sec flow rate</p>	<p>Yard drain <i>Alrondo</i></p> <p>made of polymer, vertical outlet</p> <p>With integrated odour trap.</p> <ul style="list-style-type: none"> <input type="checkbox"/> cover plate 200 x 200 mm with round slotted cover Ø 140 mm made of polymer, screwed <p>Can be driven over by vehicles of up to 2 ton.</p>	<p>Ø 110</p>	<p>37 287 S</p>

Yard drains in *Ecoguss* / polymer System 200 / 100

Installation example yard drains System 200



- ① Upper section and cover
- ② Odour trap (Art. # 27 171)

Ecoguss yard drains assure an efficient surface water drainage of outdoor areas. Included is the upper section and cover which handles vehicle traffic loads up to 12.5 metric tons. An optional odour trap can be used to keep unpleasant sewer odours where they belong.

Installation example yard drains System 100



- ① Upper section and cover
- ② Concrete
- ③ Sludge basket
- ④ Locking system

Ecoguss yard drains assure an efficient surface water drainage of outdoor areas. Included is the upper section and cover which handles vehicle traffic loads up to 12.5 metric tons. In the case that upper section and cover are used alone (without being connected to a drain body) it is important that voids are properly filled with concrete to provide the required support. The integrated sludge basket is easily accessible for cleaning via the *Lock & Lift* cover removal and locking system.

Professional advantages

- **Vertically adjustable upper section** for stepless installation in concrete slabs: rotatable, tiltable and vertically adjustable up to 110 mm
- **Deeper installation and lateral inlet requirement.** In one step the quick and easy solution. With extension section Art. # 67 500 and extension Art. # 67 600 with \varnothing 110 lateral inlet.
- **Frost free installation depth up to 1020 mm** with extension section Art. # 67 500.
- **Locking and removal key** for *Ecoguss* drain covers with *Lock & Lift* System. Art. # 67 007.

Professional advantages

- **Multistop** as an odour, foam, rodent and insect protection (Art. # 48 500) available as accessory.
- **Locking and removal key** for *Ecoguss* drain covers with *Lock & Lift* System Art. # 67 007.
- **Compact and low weight** alternative to cast iron drains
- **Single piece pipe connection drain**
- **With sludge trap**