

# Grease separators for underground installation

**Euro G**

**NS 1 - 4**

Illustration	NS	Weight	Installation depth D in mm	Cover class A/B Article #	Cover class D Article #
	<b>1</b> NS 1	111 kg	550 to 950	<b>93 001/80 B</b>	<b>93 001/80 D</b>
	NS 2	120 kg	550 to 950	<b>93 002/80 B</b>	<b>93 002/80 D</b>
	NS 4	130 kg	550 to 950	<b>93 004/80 B</b>	<b>93 004/80 D</b>
	<b>2</b> NS 1	111 kg	800 to 1200	<b>93 001/120 B</b>	<b>93 001/120 D</b>
	NS 2	120 kg	800 to 1200	<b>93 002/120 B</b>	<b>93 002/120 D</b>
	NS 4	130 kg	800 to 1200	<b>93 004/120 B</b>	<b>93 004/120 D</b>

**Delivery:**  
System completely assembled.

**Accessories** see page 291-293:  
Sampling chamber, extension section,  
direct disposal, *SonicControl* (NS 2 and NS 4).  
Pumping stations see chapter 3 "lifting stations".

**Certification: Z-54.1-440**  
Change pending

**Grease separator Euro G NS 1/2/4**  
 in accordance with EN 1825 and  
DIN 4040-100, made of polyethylene

**For underground installation**  
Upper section made of polymer,  
infinite height and level adjustment,  
with cover class A/B, D in accordance  
with EN 124 made of cast iron,  
sealed odour-tight, incl. lift-out key.

- 1** for ground installation frost-free depth 800 mm
- 2** for ground installation frost-free depth 1200 mm

**Resistant when installed  
in the groundwater up to 500 mm**  
**A load distribution plate must be  
provided for class D.**

**Further nominal sizes on request**

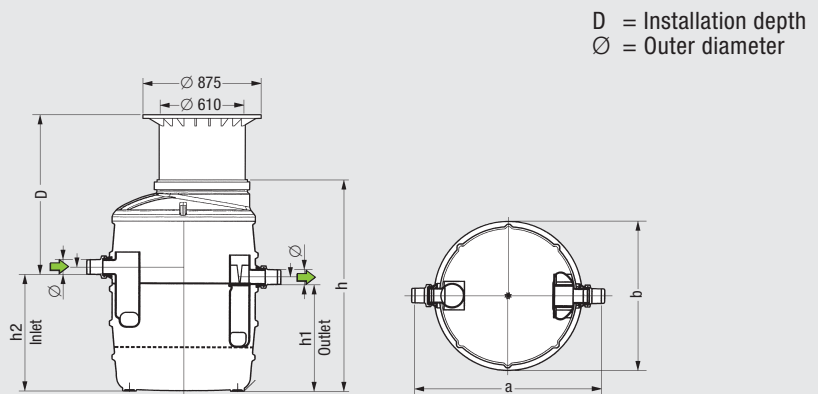

Nominal size	Ø	a	b	h <sup>1)</sup>	h1	h2	Sludge	Grease	Total (including water)
NS 1	110	1380	1106	1050	540	610	140 l	70 l	370 l
NS 2	110	1380	1106	1300	790	860	200 l	120 l	570 l
NS 4	110	1380	1106	1550	1040	1110	400 l	160 l	770 l

<sup>1)</sup> Specifications apply for type 80. For type 120, h\* = h + 250 mm.

D = Installation depth  
Ø = Outer diameter